

HOME OFFICE SYSTEM

'Work-from-home' Furniture Ideabook

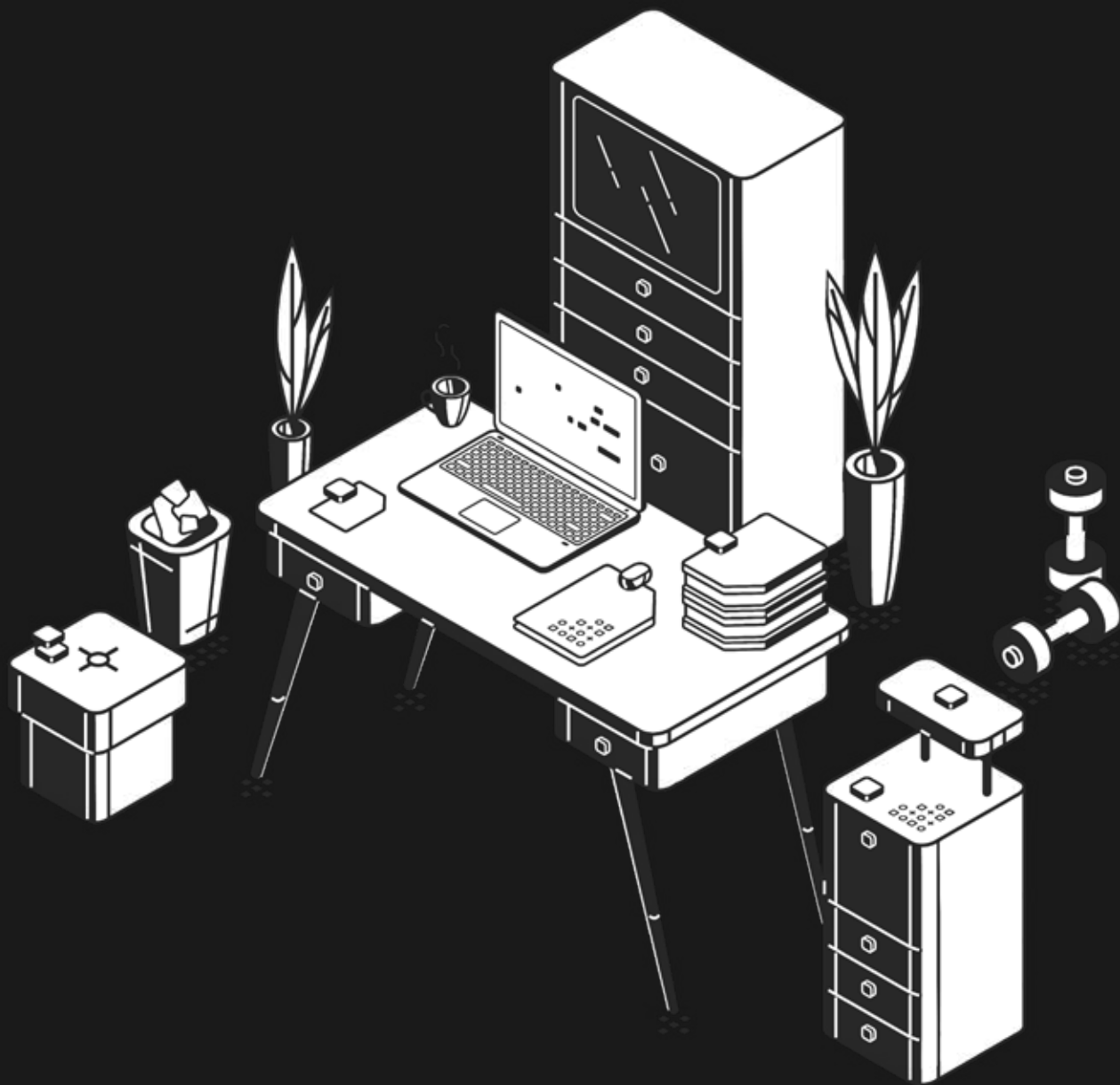



* Refer Website

Warranty

For Warranty
please refer to website.
www.hettich.com/in



Free Design Service:

Looking for Designs to liven up your Living Room, Bedroom, Bathroom & Kitchen. A dedicated team of highly qualified Interior Designers is at your service to provide customised design solution to suit every taste and budget at zero cost to you.

Free Consultation at your doorstep:

Looking for a perfect furniture fitting solution? A dedicated team of highly qualified professionals is at your service to provide the perfect furniture fittings solution to suit your need and budget at zero cost to you.

Hettich Customer Care Service:

In today's fast paced and technologically advanced era, most of the organizations succumb to the pressure of staying ahead in the competition and often, end up neglecting the most critical aspect of business i.e. CUSTOMERS. Hettich, being a CUSTOMER CENTRIC organization, is very sensitive towards this tendency; hence, we constantly try to provide the best and quality driven products and services.

Enquiry & Customer Services

Toll Free : 1800 209 2096 (office hours)
Email: sales_enquiry@in.hettich.com
customer_services@in.hettich.com
www.hettich.com

Free Training Services:

Free Training Services for carpenters of trade partners and customers

Training Center Address:

Hettich Poddar Wood Work Institute
Plot No.2, First Floor,
DLF Industrial Estate - 1
Near NHPC Metro Station
Faridabad, Haryana

Email: info@hpwwi.com
Ph: 0129 - 4203888



Hettich Poddar
WoodWorking
Institute
Skiiling • Upskiiling • Reskiiling

HOME OFFICE SYSTEM

Work From Home Furniture IdeaBook

About Us



The company's origins date back to 1888, when Karl Hettich began making the new clock component he had invented. By 1930, his descendants had diversified into furniture fittings, setting up production in East Westphalia – a center of the German furniture industry.

Today, Hettich, still family owned, has become an industry leader with a worldwide reputation. We're one of the world's largest manufacturers of high-quality furniture fittings, with over 6,000 employees in more than 100 countries. The company's success has been built on four enduring values: quality, innovation, close cooperation with customers and absolute reliability. We work to inspire our customers with our ideas and our passion.

Contents

Eight Elements of Home Office Design	11
Home Office Furniture Ideas	13 - 63
Sliding & Drawer System, Hinge Technology	64 - 71
Covid Sensitive Office Design	72 - 73
Links to Reach Us	74 - 75

About two-thirds of the 4.3 million ITBPO workforce across the country have moved to a **work-from-home** model to keep services uninterrupted during the lockdown. Experts say some companies are likely to move to WFH permanently.



Visualizing a Scenario

Imagine, your office chair is your couch and your commute is the length of your hallway. Your snack drawer is your entire pantry. Do you think it's a dream? No! Since work-from-home is very much a reality these days due to the current pandemic crisis. Now some of them find it hard and struggle to do with many reasons behind it such as dividing work time and personal time, noisy neighbors, being indolent and many other distractions at home.

However, since most of the homes are not designed to also function as offices, it leads to distractions and dip in productivity.

We at Hettich have been at the forefront of recognizing the need for such solutions and accordingly have designed innovative work-from-home furniture solutions that will enable one to work comfortably and productively.



Eight elements of home office design



Location is the key.

Home offices come in many different shapes and sizes. It can be in a separate room, a quiet corner or even in your kitchen. The key to selecting the right place for your home office is to think about where and when you do your work.

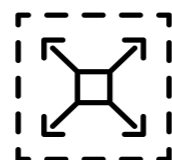

Allow enough space.

Make sure you allow enough space to work comfortably. Ask yourself if you will be able to move easily from side to side, stand up and sit back from your desk.



Colour is important.

Colour is a super important detail. The wrong colour can have a negative effect on your desire to spend time in this room and can even hinder productivity. Pay special attention to your personal colour needs.



Invest in a great chair.

A chair is just as important, if not more important than the desk. Choose a chair that fits your body and promotes proper posture while working.



Desk is an essential.

A proper desk is the key to working comfortably from home. You need to like sitting on it because unless you feel comfortable, work might become a drudgery.



Let there be light.

Good lighting is critical for any home office space. Choose a location with some natural light and a view, if possible. Position your desk to face the windows or in a location where your computer screen will not be affected.



Organization is a necessity.

Storage is often overlooked when designing a home office and can really affect your productivity. Make sure to include enough shelving, filing cabinets or cupboards for your storage needs.



Inspire yourself.

Set up a mini-shrine — a few cherished knick-knacks, a piece of framed art, a special photo on your desk — that motivates you to create and/or get the work done so you can get out of there.



Home Office Furniture Ideas

In these uncertain times, our working has also evolved and work-from-home has become the 'New Normal'.

This book is a collection of practical and easy to implement Home Office furniture ideas with a good balance of aesthetics and functionality.

The most productive corner of the house.

Every house is different. It comes in varied shapes and sizes. In this concept, we have tried to showcase how one can create a neat working corner in the house, which has every element of the work office including a good desk.



FITTINGS USED

1. SlideLine M
2. Quadro Runner
3. Itri- Pro Decor Handle

CMF USED

White & Grey Wood
Matte Finish



Busy like office; calm like home.

This is a great solution for those who want to enjoy the best of both the worlds. For those who wish to catch all the LIVE action on TV in the living room, while doing all the office work, this is just the perfect solution.



FITTINGS USED

1. WingLine L
2. Sensys Hinge
3. LegaMove

CMF USED

Grey & Oak wood
Wood Matte Finish



Tired of sitting and working? Then stand and deliver!

While one normally sits and works, at times, fatigue sets in necessitating a need for a break and change of position. The standing work desk is just the ideal solution for those who like to stand and deliver.



FITTINGS USED

1. WingLine L
2. WorkTop Extension
3. ArciTech Drawer System
4. Lano SQ 30- Leg

CMF USED

- Oak wood
- Graphite Grey Wood
- Matte Finish

Your workstation is the catalyst for your work productivity.

Save up on space and at the same time make it relaxing. Engage yourself with increased concentration and focus with the spacious work desk and overhead storage spaces. After all, a clean and organized office makes work more productive.



FITTINGS USED

1. SlideLine M
2. ArciTech
3. Versa 60

CMF USED

Graphite grey &
Orchard Delight
Wood Matte Finish



An office away from an office.

This office is designed for those who have an extra room in their house and can therefore convert it into a home office to work in perfect solitude. It is especially designed to give one the feeling of sitting in one's own office while actually working from home.



FITTINGS USED

1. CUBE
2. SlideLine M
3. Systema 2000
4. Comfort Spin

CMF USED

- White & California
Walnut Wood
Matte Finish



Different applications of OrgaTower

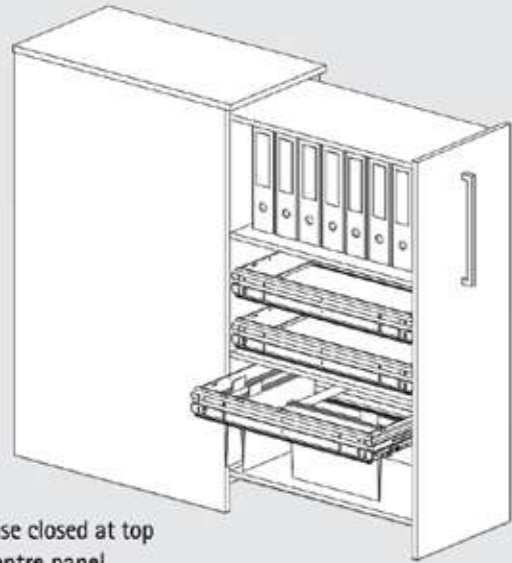

- Inner carcass closed at top
- Without centre panel
- 1 x folder stand
- 2 x wide drawer with over extension runner
- 1 x file cradle with over extension runner (1 row parallel with front + remainder parallel with side)

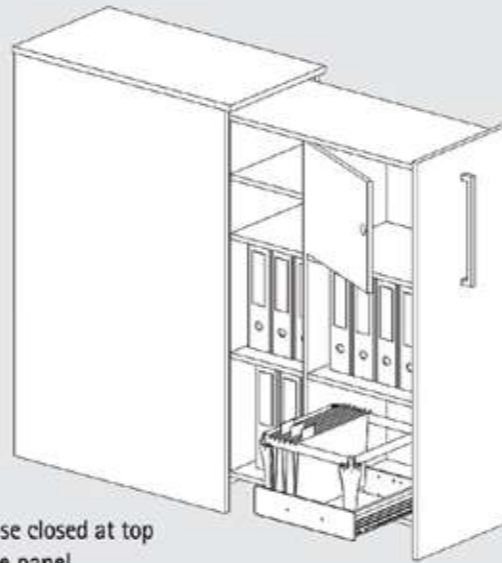

- Inner carcass closed at top
- With centre panel
- 1 x hinged door with Push to open
- 1 x folder stand
- 1 x A4/A4 drawer with slot in file cradle, EB 392; over extension runner

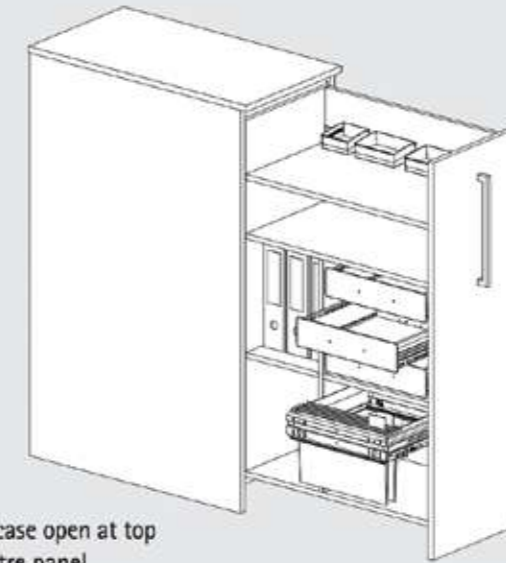

- Inner carcass open at top
- With centre panel
- 1 x Org@Wall profile with trays
- 3 x A4/A4 drawer with steel front panel, EB 392; over extension runner
- 1 x file cradle, A4, with over extension runner

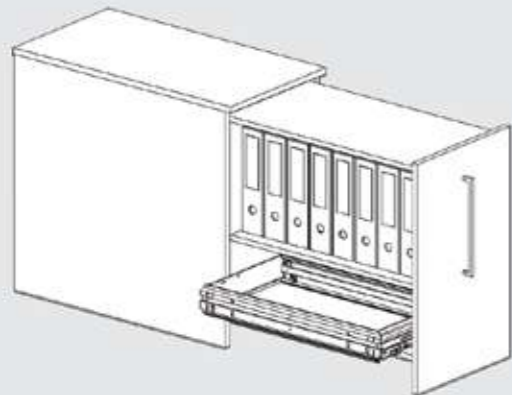

- Inner carcass open at top
- Without centre panel
- 1 x folder stand
- 1 x wide drawer with over extension runner

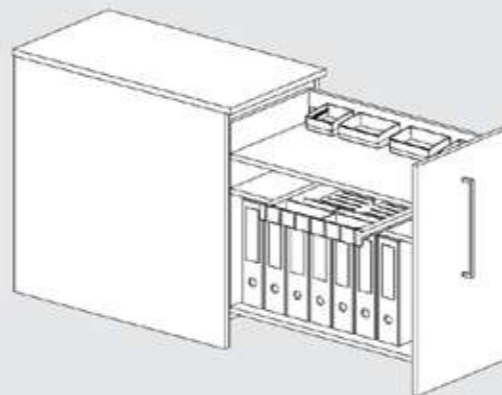

- Inner carcass open at top
- Without centre panel
- 1 x Org@Wall profile with trays
- 1 x SmarTray Plastic 40 mm with side connection, partial extension runner
- 1 x folder stand

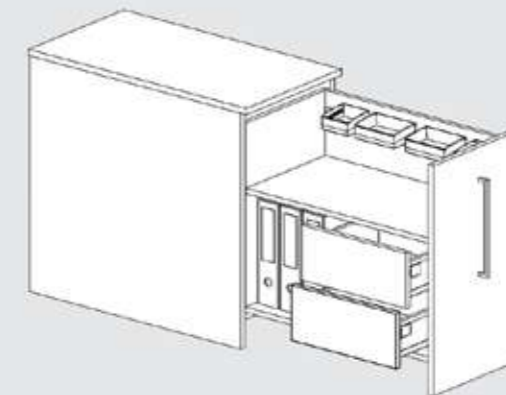

- Inner carcass open at top
- Without centre panel
- 1 x Org@Wall profile with trays
- 2 x SysTech drawer system with wooden front panel; over extension runner



Scan QR For Details

Work station on weekdays; game station on weekends.

Be mesmerized with simple and bold forms, engage your senses with optimal storage space, where you can combine your activities of work and play.



FITTINGS USED

1. AvanTech YOU
2. SlideLine M

CMF USED

White & Walnut Wood
Matte Finish



Compact yet high on impact.

An ideal solution for those who want their work stations to be as compact as possible without compromising on the productivity and the organizing space.



FITTINGS USED

1. CUBE
2. SlideLine M
3. Versa 60

CMF USED

- Black Wood
Matte Finish

When home office is the only office.

This office is specially designed for entrepreneurs who have started their business from home. This office is situated on the terrace and has the aesthetics of a grand office to create a lasting impression on one's clients. It is well-equipped for a single person office needs.



FITTINGS USED

1. Grant 400 Neo
2. SlideLine M

CMF USED

Grey & Acacia wood
Wood Matte Finish



Different applications of Table Leg



Swivel castor with premounted pin for edge protection

- Load capacity 80 kg per castor
- $\varnothing 75$ mm
- For hard and soft floors

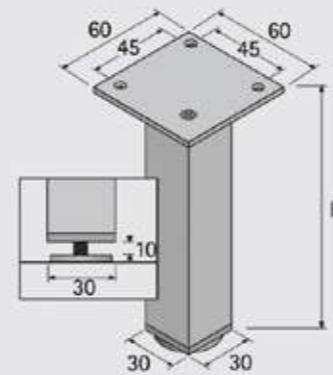

Lano SQ 30

- Square tubing, 30 x 30 mm
- With + 10 mm floor levelling via adjusting screw
- Load capacity 150 kg per furniture stand
- Mounting plate powder coated steel, silver
- Furniture stand aluminium

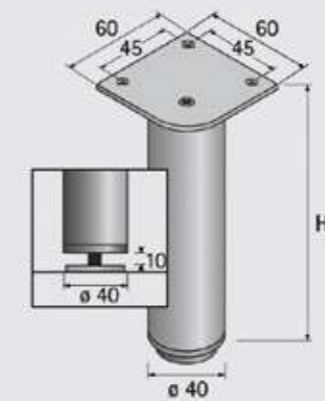

Lano RO

- Diameter 40 mm
- With + 10 mm floor levelling via adjusting screw
- Load capacity 150 kg per furniture stand
- Mounting plate powder coated steel, silver
- Furniture stand aluminium



Afia

- Length 700 mm
- Square tubing, 60 x 60 mm
- Load capacity 150 kg per table leg
- With + 10 mm floor levelling
- Brushed stainless steel



Afio

- Length 700 mm
- Square tubing, 60 x 60 mm
- Load capacity 150 kg per table leg
- With + 10 mm floor levelling
- Brushed stainless steel



Femi

- Length 650 / 710 mm
- Diameter 60 mm
- Height adjustment + 100 mm, infinitely height adjustable up to 750 / 810 mm
- Load capacity 150 kg per table leg



Scan QR For Details

For that extra office storage without impinging on the look of the house.

There are times when you want to store those extra office files and other important things but just don't have enough space. While the living room becomes your go-to place, it ends up spoiling its beauty. This storage unit provides just the ideal solution to hide those extra files as well as showcase your prized possessions.

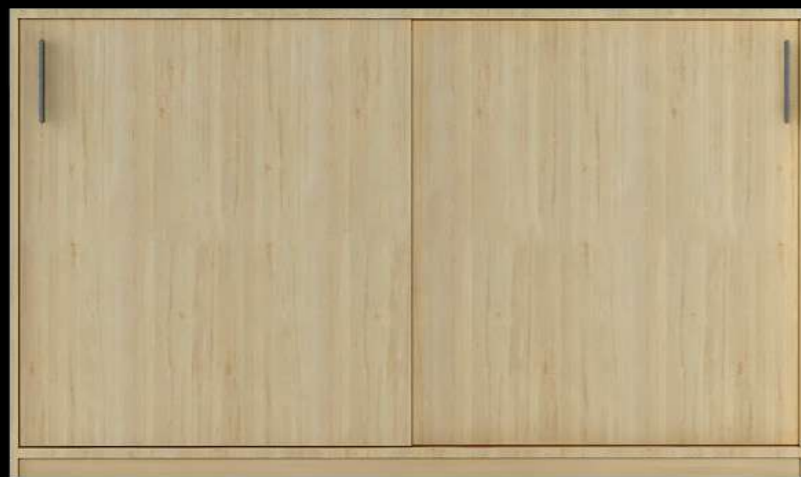

FITTINGS USED

1. CUBE
2. Lega Drive
3. SlideLine 56

CMF USED

- Oak Wood
Wood Matte Finish

Working in style, while being at home.

Elegantly combining home living and working - it's never been as easy as it is today. Practical yet at the same time stylish; in a small space yet ergonomic - Sliding door systems meet many demands all at once. Because they take up little space and impress with their functionality & homely appeal. Height adjustable desks ensure a back-friendly work posture at home too, apart from making an innovative design statement.



FITTINGS USED

1. Vertico Synchro
2. SlideLine 66
3. LegaDrive

CMF USED

White & Grey
Wood Glossy Finish

Slide for office; glide for library.

Ideal solution for professionals who don't need a dedicated space for work. Since they don't have to use it all the time, it serves a dual purpose of storing books without occupying too much of space.



FITTINGS USED

1. WingLine L
2. SlideLine M
3. Quadro Runner

CMF USED

Grey & Oak Wood
Wood Matte Finish

Big on storage for those big on responsibilities.

This home office is ideal for senior professionals who have loads of responsibilities on their shoulders and consequently loads to store. Equipped with ample storage, it is perfect for storing business reports, files, awards and those prized collection of books.



FITTINGS USED

1. OrgaTower
2. SlideLine M
3. Eco Spot-Light

CMF USED

White & Oak Wood
Wood Matte Finish



Different applications of LegaDrive

Basic desk support set

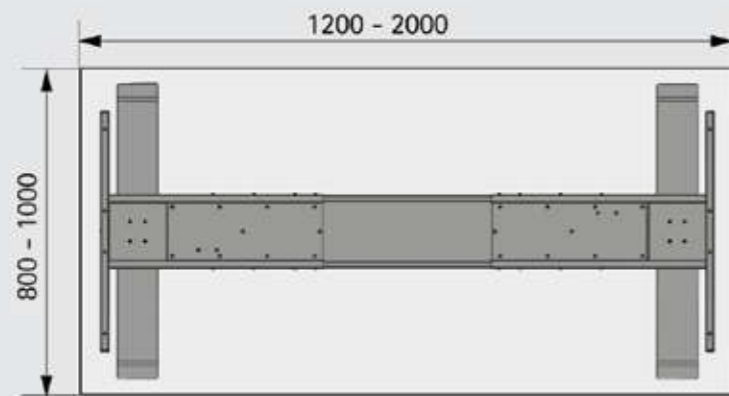

90° angle desk support

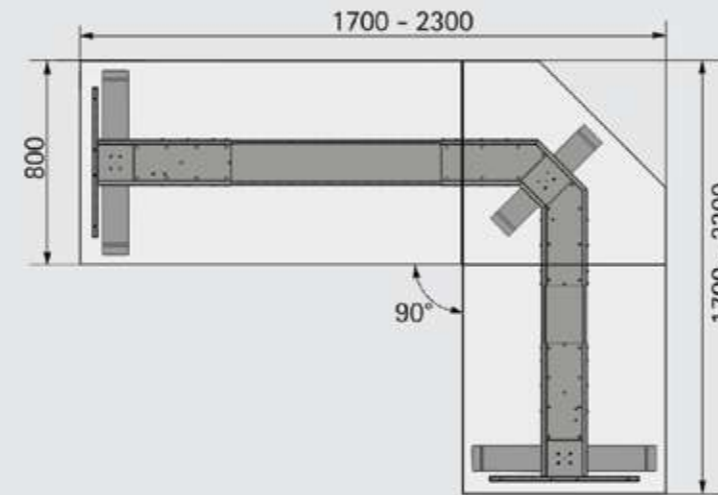

135° angle desk support

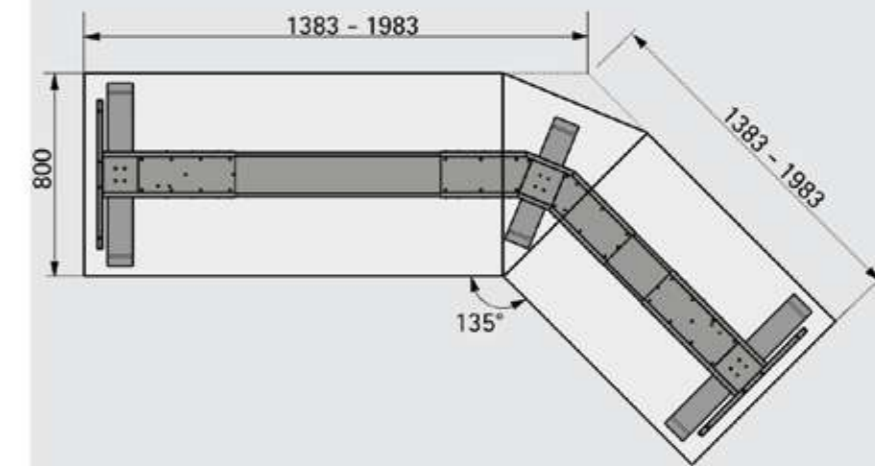

U shaped desk support

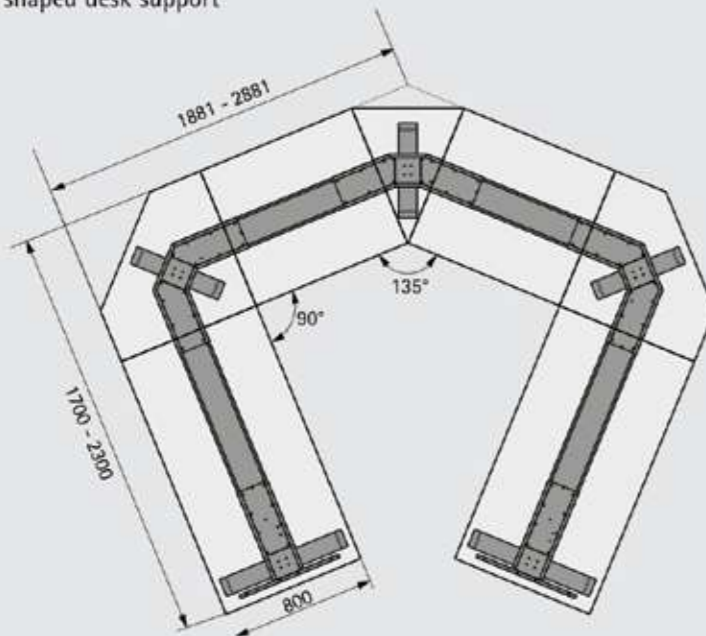

Conference table, round

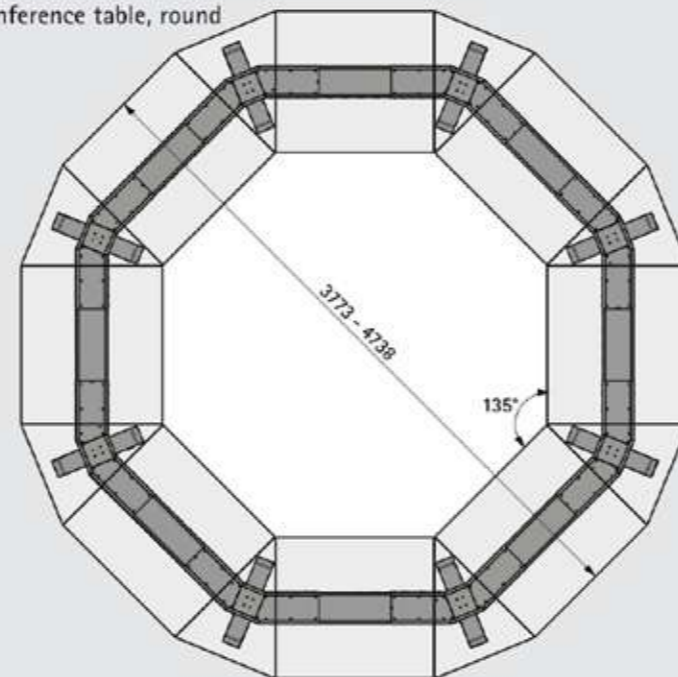

LegaDrive

The healthier, more efficient way to work – with LegaDrive Systems. Height adjustable desks and tables are becoming more and more popular in office and contract furnishing.

- For variable desk top sizes:
depth 800 - 1000 mm
width 1200 - 2000 mm
- Desk top support frames adjustable in width in increments of 50 mm
- Power assisted height adjustment from 620 - 1295 mm
- Lifting range 675 mm
- Max. lifting capacity 120 kg with even desk loading
(lifting capacity = load capacity + desk top with desk top support)
- Height adjustment with soft start
- Nominal voltage 230 V / 50 Hz
- Low energy consumption (standby 0.3 W max.)
- Speed 40 mm/s
- With collision detection (no personal protection)



Scan QR For Details

When study area becomes an office.

This office is designed for those people who have converted their study room into a home office. It still imbibes the feel of a study area where one can unwind oneself with a cup of coffee and one's favourite book without compromising on productivity and storage space.



FITTINGS USED

1. CUBE
2. LegaDrive

CMF USED

Black & White
Wood Matte Finish



A space to lie down with a space to work.

This neat and minimalistic home office work station is designed for those individuals who work for long hours and wish to have a small power nap in the same room.

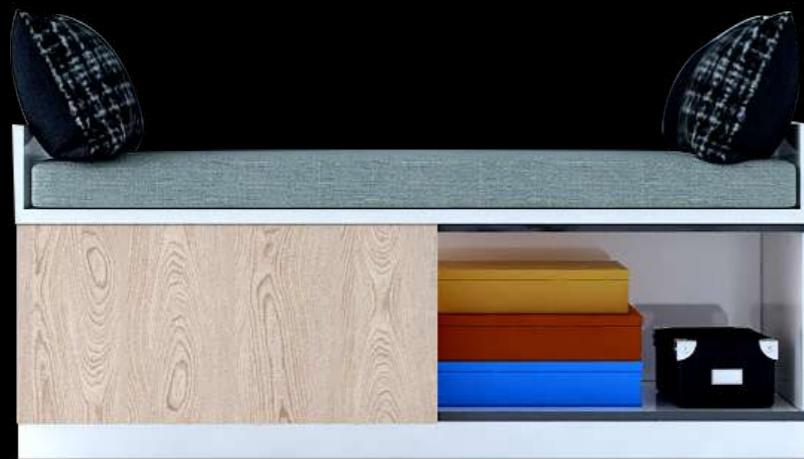

FITTINGS USED

1. SlideLine M
2. Lega Drive
3. CUBE

CMF USED

White Wood
Matte Finish



Win storage; feel style.

There are times when you want to store those extra office files and other important things but just don't have enough space. While the living room becomes your go-to place, it ends up spoiling its beauty. This storage unit provides just the ideal solution to hide those extra files as well as showcase your prized possessions.



FITTINGS USED

1. TopLine 80
2. WingLine L
3. Versa 60
4. Afia-Table Leg

CMF USED

Black Leatherette
Matte Finish



Work from home is more effective with natural light.

It is a proven fact that when there is a natural source of light in the workplace, it becomes more productive. In this design, we have carefully thought of bringing life to the work desk with natural light and a good storage space to organize one's files.



FITTINGS USED

1. AvanTech YOU
2. CUBE
3. Lift Advanced HK

CMF USED

Metallic Copper Wood
High Gloss Finish



Different types of Organizers



Smar Tray

- In the carcass or under the desk top
- Lockable (SmarTray Steel only)
- Complete range alternatively available in plastic or steel



ComfortSpin

- Movable platform not only turns contents through 360 degrees but also moves them out slightly
- Making everything easy to reach



Organisationell system Org@Wall

- Screening and sound barrier
- Utensils and things needed every day in the office are always neatly organised
- Great flexibility, easy installation



Pencil Tray

- Integrated practical compartments
- Tidy organisation made easy
- Items easier to find



OrgaStripe Profile

- For sticking onto coated engineered wood, steel and aluminium
- Length 1100 mm
- Plastic



File Cradles

- A simple matter with the robust hanging file frame.
- For hanging files A4 size
- Steel, nickel plated / plastic



Scan QR For Details

All the space you want without taking much space.

Ideal for those who need a spacious and well-organized set-up to sit comfortably and attend meetings or classes.



FITTINGS USED

1. TopLine 80
2. OrgaTower
3. SlideLine M
4. Lift Advanced HL

CMF USED

Grey & Oak Wood
Wood Matte Finish



Working in solitude.

For those attuned to working in perfect solitude, this home office provides a perfect serene environment for enhancing concentration and productivity.



FITTINGS USED

1. AvanTech YOU
2. SlideLine M
3. Vertico Mono
4. Versa 90
5. Franke

CMF USED

Black and Dark Oak
Wood Matte Finish



The hidden home office.

There are times when you do not want your home office to be apparently visible. The hidden home office is just the perfect solution for those who want the functionality of the office without compromising on the decor of the room.



FITTINGS USED

1. SmarTray
2. Sensys Hinge
3. Versa 60

CMF USED

White & Oak Wood
Wood Matte Finish



Invisible home office.

Living and working under one roof in small spaces will no longer be a hassle! Thanks to just one exclusive piece of furniture. Closed, it's a glass display cabinet with a homely character and distinctive design aspects. Open, this multifunctional furniture solution is transformed into a cleverly configured workplace.



FITTINGS USED

1. Sensys Hinge for glass applications
2. SlideLine M
3. Actro Runner, Push to Open
4. Flap Fitting

CMF USED

- Glass
- Charcoal Black
- Soft Cushion



Minimal design; maximal utility.

Some spent a long time at the study table during this lockdown because it became their office. Consequently, the need for furniture to be fully functional with ease of access to all basic accessories like stationery, books etc. And at the same time, minimalistic without occupying too much space.



FITTINGS USED

1. CUBE
2. SlideLine M
3. LegaDrive
4. Versa 60

CMF USED

Grey & White
Wood Matte Finish



Different types of Sliding Systems



WingLine L

- Overlay door position
- Push / Pull to move
- Door wing weight up to 25 kg



Grant 400 Neo

- Door weight max 40kg /per
- Cabinet width max. 1200 mm
- Door height up to 3500 mm



TopLine 80

- Door weight max 80kg /per
- Cabinet width max. 1200 mm
- Door height up to 2500 mm



SysLine S

- 2-track, top running sliding door system for inset door position
- For sliding doors weighing up to 15 kg
- For doors in widths of 400 - 800 mm



SlideLine 55 Plus

- 2-track, bottom running sliding door system for inset and overlay door position
- For sliding doors weighing up to 15 kg and using a plastic profile
- For sliding doors weighing up to 30 kg and using an aluminum profile



SlideLine M

- Single-track sliding door system for overlay door position
- For sliding doors weighing up to 30 kg
- Can be used for wooden, aluminum framed and glass doors, making it extremely versatile

Different types of Drawer System & Hinge Technology



AvanTech

- Double walled drawer system for particularly high quality
- Actro 5D drawer runner for top running performance
- 40, 60 and 80 kg loading capacities



ArciTech

- Excellent running action, perfect Silent System performance
- 40, 60 and 80 kg loading capacities
- Platform concept for different design options



Atira

- Distinctive, sleek design
- Various colour options
- Quadro drawer runner with a loading capacity of up to 50 kg



Sensys

- Fast assembly concealed hinge with integrated Silent System
- Wide self closing angle from 35°
- 3-dimensional door adjustment



Intermat

- Fast assembly concealed hinge without Silent System
- Not visible from the outside
- 3-dimensional door adjustment



Selekt Pro 2000

- Single pivot fast assembly concealed hinge with optional Silent System
- 2-dimensional door adjustment
- 180°- 270° opening angle

Summary of Office Accessories

Locks

The different design options of Locks for office furniture.



Cylinder Case Lock



Cylinder Push Lock



Drawer Cylinder Case Lock

Cable Management

The different design options of Cable Management for office furniture.

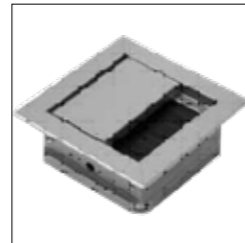

Cable Entry, Aluminium, 70 Mm / 70 Mm



Cable Entry, Metal / Brush, Round



Cable Entry, Aluminium, 120 Mm / 300 Mm

Handles

The different design options of Handle for office furniture.



Intra



Alano



Agacia

Lights

The different design options of Lights for office furniture.



Eco Spot



Powerlite Plus



EcoPower L

Trays & Comfort Spin

The different design options of Trays for office furniture.



Pencil tray, height 25 mm



Pencil tray, height 40 mm



ComfortSpin

Castors

The different design options of Castors for office furniture.



Bala Drive Designer Twin Wheel Castor With Plain Bearing



Bala D-Lock Twin Wheel Castor With Brake And Plain Bearing



Asim Fix Side Castor For Hard Floors With Plain Bearing



Scan QR For Details

Home Office Furniture Modules



Making the Open Office Covid-Resistant.

With nearly 7 million people affected by the coronavirus pandemic, organisations will need to redesign workspaces, stagger work hours and retrofit furniture to ensure the safety of employees. Here's a look at some solutions.

1. Higher space division creates separation and psychological comfort.
2. Sanitation stations provide easy access to cleaning supplies.
3. Changing the arrangement (geometry) of the desks reduces face-to-face orientation.
4. Individual seating in lounge spaces help to maintain a safe distance.
5. Added video conferencing enclaves enable remote collaboration, allowing fewer people to work in the office at the same time.

Pre-Covid Office

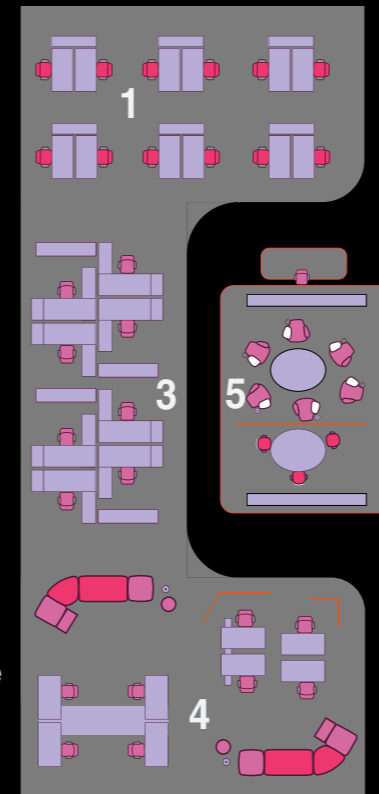

The New Normal

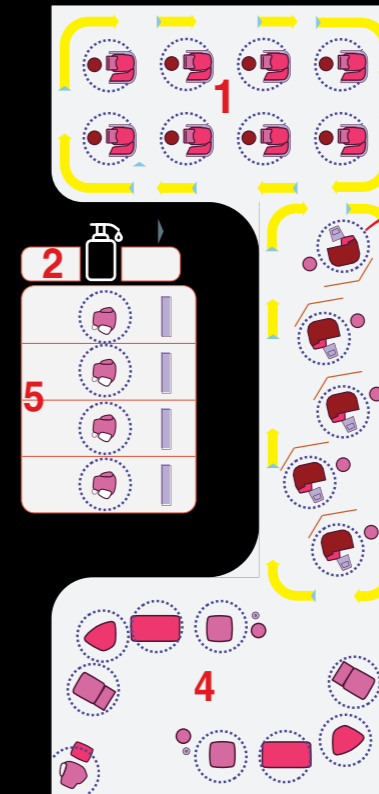

Minimum Distance

Create minimum 6ft/2m distance between people in open workstations, meeting spaces, cafés and lounge spaces.

Clockwise Movement

Use neon strips to mark a path for people to walk on, in a clockwise direction, to prevent accidental face-to-face encounters, and regulate movement between workstations.

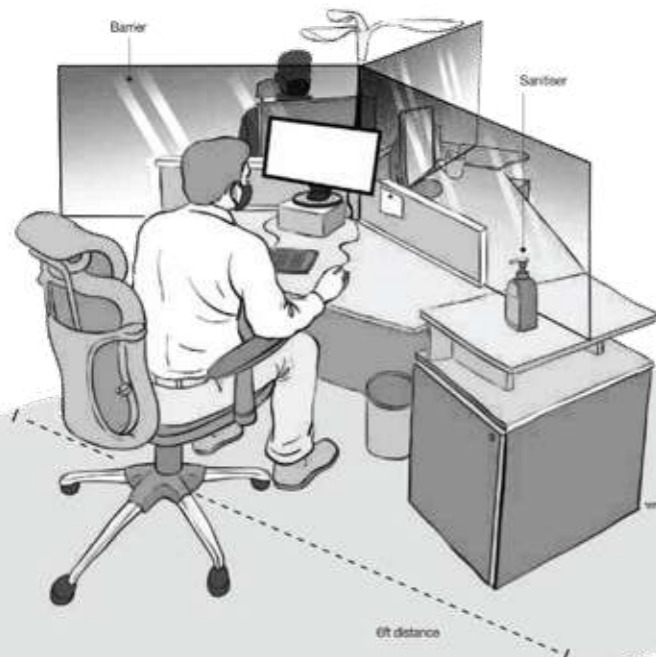

Design

The open office can be made safer for employees through the practice of design thinking. Here's a look at some solutions.

Density: Rearrange the floor plan so that no two people are sitting next to or directly facing each other; use diagonal seating arrangements, or leave alternate desks vacant.

Realign: Separate furniture pieces that allow multiple people to use them.

Barriers: In the case of close, clustered spaces, use shields to protect workers, if distancing of 6ft/2m is not possible.

Touch points: Eliminate touch points like switches, doorknobs, biometric entry and attendance systems.

Head out: If the office has a gym or a canteen, see if they can be moved out into natural light and air, with adequate distancing; employees must sanitise equipment before and after each use.

Flow

Reduce footfall by staggering work hours and work days to decongest office spaces.

Receptions: Expand receptions, arrange to meet people at the entrance rather than in office meeting rooms.

Meeting rooms: Open up, allow ventilation, natural light; change furniture set-up; avoid closed-room meetings.

Clustering: Reduce use of cluster points like central meeting tables, pantry.

Neon strips: Encourage people to move in a clockwise direction only, to avoid bumping into each other.

Water-cooler talk: Encourage people to use masks and maintain 6ft distance from each other even during casual interactions; discourage the use of water coolers, pantries and common dining spaces as these are high-cluster zones.

Lifts: Stagger employees' arrival times to prevent logjams at the lifts; Limit the number of people travelling in each lift.

Sanitation

Take particular care in meeting areas and toilets, near water coolers and coffee machines.

Disposable paper pads: Line workstations with disposable paper pads to keep them sanitary; encourage employees to be responsible for the hygiene of their desks.

Sanitation stations: Place hand sanitiser at multiple locations for people to use repeatedly; encourage people to bring their own too.

On-the-clock cleaning: Sanitise the floor and workstations multiple times during the day, not just once.



Registered & Head Office:
Hettich India Private Limited
 302, Duro-lite House,
 Opp. SAB TV, New Link Road,
 Andheri (West), Mumbai - 400 053
 Phone: +91 22 2674 3289/3356/4089
 Fax: +91 22 2674 3267

Delhi Office:
Hettich India Private Limited
 A-26/4, 1st floor,
 Mohan Co-operative Industrial Estate,
 New Delhi - 110 044
 Phone: +91 11 4889 4000, 4889 4005
 Fax: +91 11 4889 4044

Vadodara Factory:
 Plot No. 304, Dhanora,
 Nandesari Road,
 Near ECPL,
 Village - Dhanora - 391 346
 Dist. - Vadodara
 Tel: + 91 26 5656 9003

Indore Factory:
 Plot No. 1, Sector - 5,
 Mhow - Neemuch Road,
 Opp Lupin Ltd, Pithampur
 Industrial Area, Pithampur
 Madhya Pradesh -454 774

Application Centres:

New Delhi:
 61, Panchkuian Road,
 New Delhi - 110 001
 Ph. No. : +91 11 2358 0713,
 2358 4603

Mumbai:
 202, Duro-lite House, Opp. SAB TV,
 New Link Road, Andheri (West),
 Mumbai - 400 053
 Ph.No. : +91 22 2639 9707

Chennai:
 "Heavitree", Ground Floor,
 47, Spur Tank Road,
 Chetpet, Chennai - 600 031
 Ph. No. : +91 44 4263 7227

Kolkata:
 2nd Floor, Unit Number 2A,
 Tirumala 22,
 East Topsia Road,
 Kolkata - 700 046
 Ph. No. : +91 85850 44725

Hyderabad:
 " Sai Krishna "
 797 - A, Road No. 36,
 Jubilee Hills,
 Hyderabad - 500 034
 Ph. No. : +91 40 2355 8994

Ahmedabad:
 1st Floor, Unit No. 102,
 Safal Pegasus,
 Anand Nagar,
 Ahmedabad - 380 015,
 Ph. No. : +91 79 4032 2824

Bangalore:
 Adventz Center, Ground Floor 28,
 Cubbon Road, Shivaji Nagar,
 Bangalore - 560 001
 Ph. No. : +91 80 4530 0400,
 4530 0401

Kochi:
 41/2062D, 2nd Floor
 Palarivattom signal
 junction, NH 47 By-pass,
 Kochi - 682 028
 Ph. No. : +91 93 4900 3909

Indore:
 Office No.106 and 107-A,
 "Brilliant Titanium",
 Plot No.9, Scheme No.78, Part-II,
 Indore - 452 010, Madhya Pradesh,
 Ph. No. : +91 93 0171 7343

Chandigarh:
 2nd Floor, Aspire Tower,
 Plot no. 55, Industrial
 & Business park, Phase 1,
 Chandigarh - 160 002
 Ph. No. : +91 93 1755 7195

Training Center Address:
 Hettich Poddar Wood Work Institute
 Plot No.2, 1st Floor, DLF Industrial Estate-1
 Near NHPC Metro Station,
 Faridabad- Haryana
 Ph: 0129 - 4203888
 Email: info@hpwwi.com

Enquiry & Customer Services
 Toll Free : 1800 209 2096 (office hours)
 Email: sales_enquiry@in.hettich.com
 customer_services@in.hettich.com
 www.hettich.com

Scan QR Code



Visit us online:

www.hettich.com



Master Catalogue



CargoTech
Master Catalogue



Interested?
Explore Design options

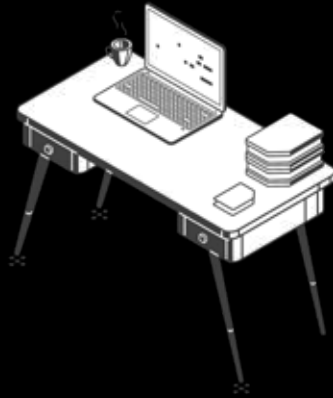

HOME OFFICE SYSTEM

Work From Home Furniture IdeaBook

Hettich India Private Limited
302, Durolite House,
Opp. SAB TV, New Link Road,
Andheri (West), Mumbai - 400 053
Phone: +91 22 2674 3289/3356/4089
Fax: +91 22 2674 3267

Enquiry & Customer Services
Toll Free : 1800 209 2096 (office hours)
Email: sales_enquiry@in.hettich.com
customer_services@in.hettich.com
www.hettich.com

Technik für Möbel

Hettich